



**SOLVENT EXTRACTION
TECHNOLOGY TRANSFORMS
BASE-METAL HYDROMETALLURGY**

Peter Cole

Mintek 75 Conference – 4-5 June 2009



A global leader in mineral and
metallurgical innovation

- § K.C Sole (2008) Solvent extraction in the hydrometallurgical processing and purification of metals. In *Solvent Extraction and Liquid Membranes*, eds. Aguilar and Cortina, 141-200. Florida: CRC Press.
- § K.C.Sole and P.M.Cole (2001) Purification of nickel by solvent extraction. In *Ion Exchange and Solvent Extraction*, vol. 15, eds. Marcus and SenGupta, 143-195. New York: Marcel Dekker

- § **Copper processing using Leach/SW/EW technology.**
- § **Selective Cobalt recovery over nickel.**
- § **Processing of Nickel laterites.**

- 1950s** SX first commercialized for uranium, South Africa
- 1968** First Cu SX plant – Bluebird, Arizona
- 1973** First large-scale Cu SX plant - Nchanga, Zambia
- 1974** First Co/Ni SX plant – RBMR, South Africa

Copper Heap Leach - Morenci



0.35% Cu grade of
oxide ore

23000 m³/h PLS

Treated in 4 SX
trains



Leach: Oxide Ore:
3.5% Cu, 0.8% Co

5 stage CCD

Fe/Mn Removal

Co(OH)_2 ppt'n



Back-to-back M/S



Low Grade SX Circuit
5-6 g/L Cu; 300 m³/h

High Grade SX Circuit
10 g/L Cu; 500 m³/h



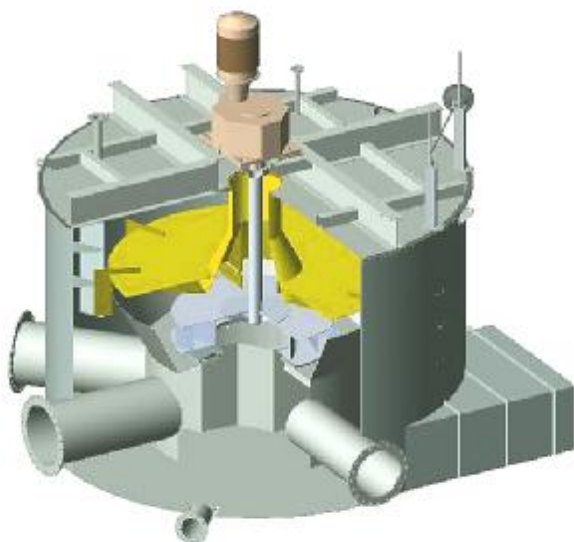

Dispersed Overflow Pumping Unit

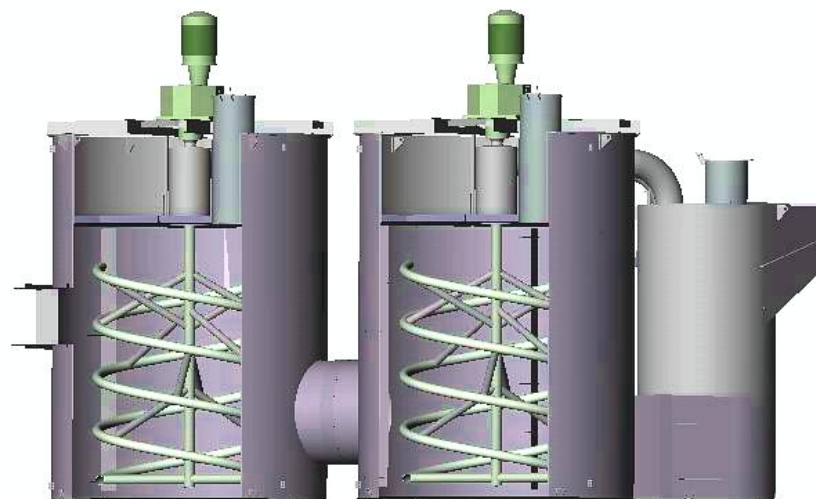

SpiroK Helical Mixing Agitators

- Escondida Sulfide, Chile (2004); 2 by 5000 m³/h SX trains, 180000 tpa Cu
- Sepon Copper, Laos (2004); 65000 tpa Cu
- Milpillas, Mexico (2004); 65000 tpa Cu
- Radomiro Tomic D Train, Chile (2000); expansion to 260000 tpa Cu

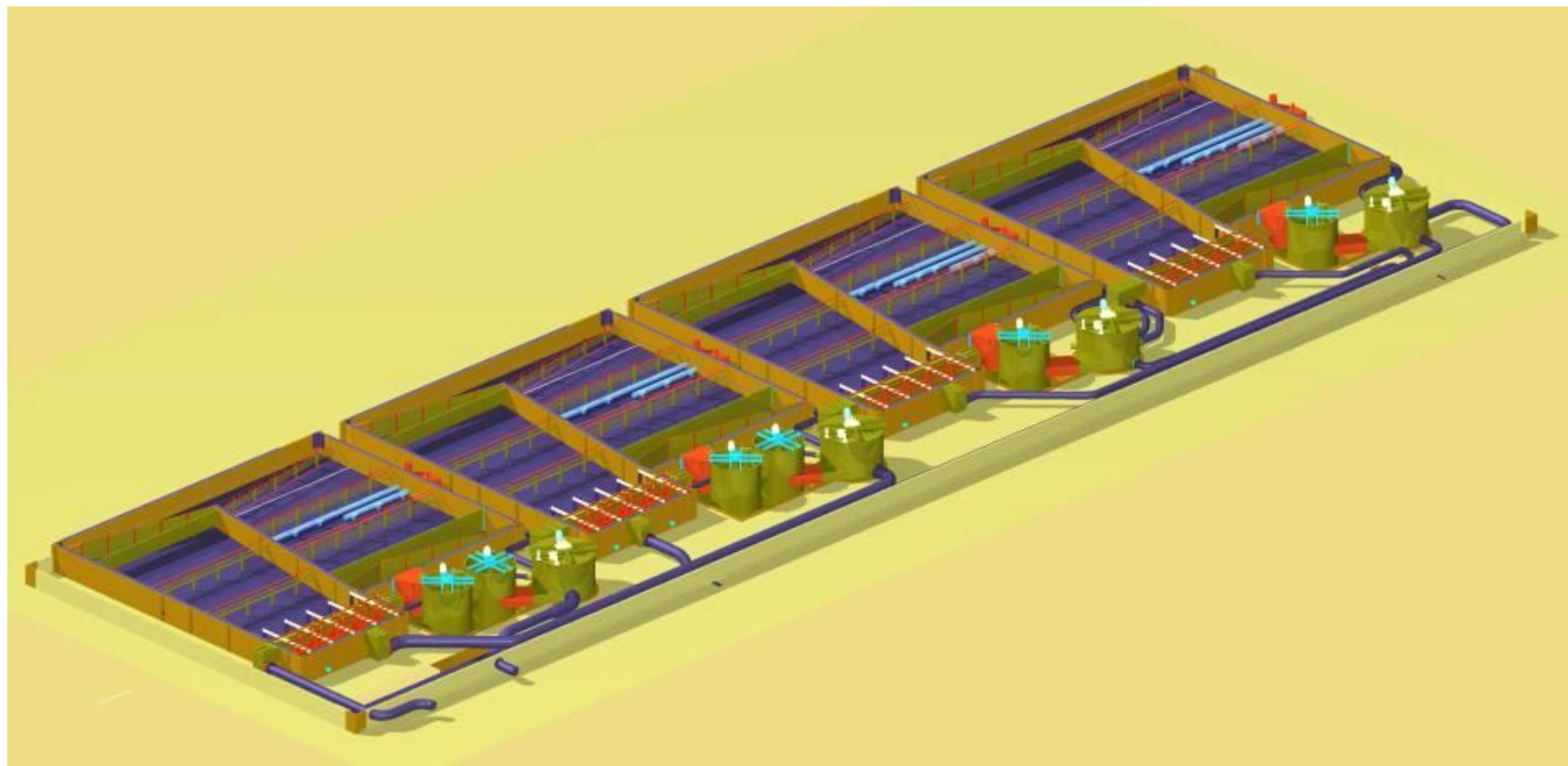

500 m³/h SX train; Reverse-flow Mixer Settlers; 65000 tpa Cu



65 000 tpa Cu; 2004



Expansion to 260 000 tpa Cu; (2000)

Copper EW Cathode (>99.99%)





Separation of Cobalt and Nickel in Sulfate

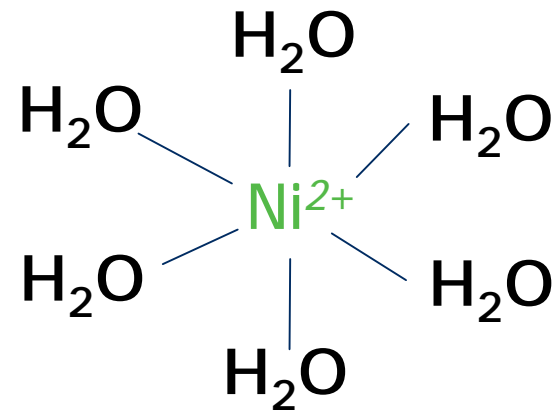
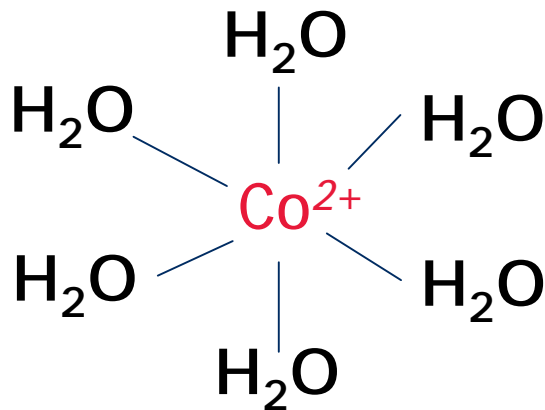

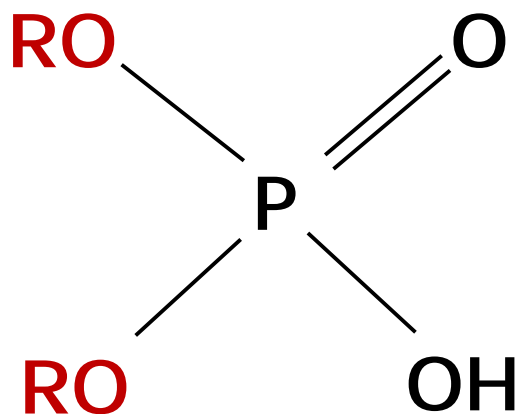

Phosphoric

D2EHPA

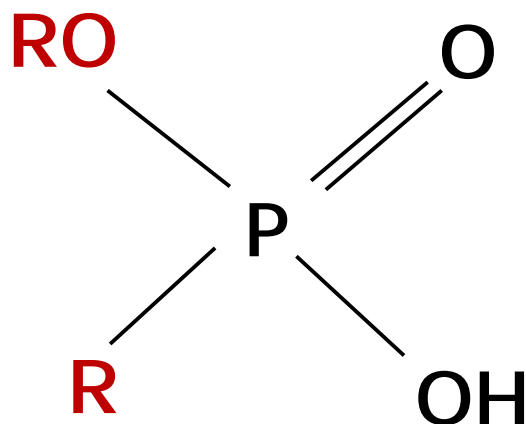

phosphonic

lonquest801

PC-88A

P507

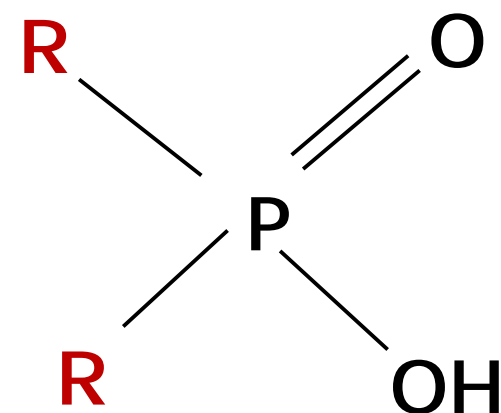

phosphinic

CYANEX 272

lonquest 290

LIX 272

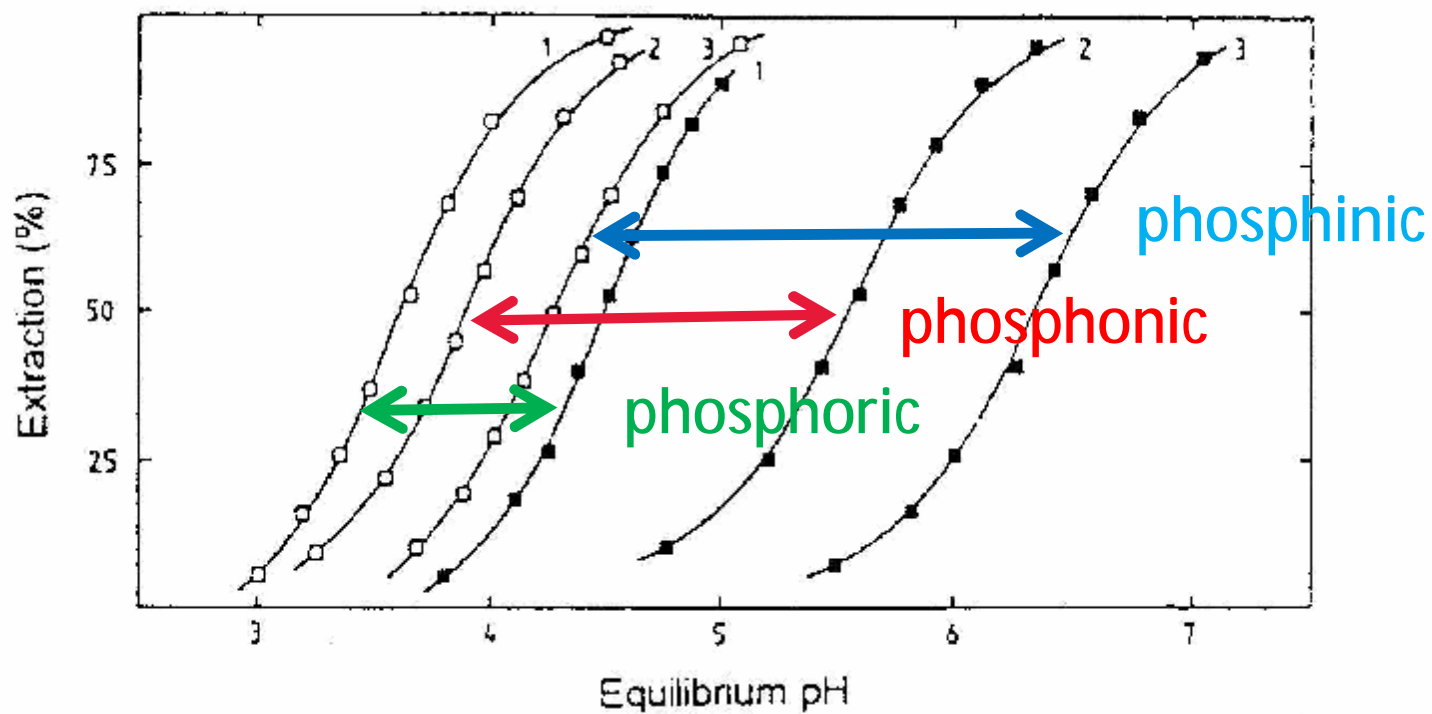

		<u>Co:Ni</u>
D2EHPA	RBMR, South Africa	10
PC-88A	Nippon Mining, Japan	300
P507	Jinguan Nickel, China	300
CYANEX 272	40% of world Co	7000

Solvent Extraction in Laterite Processing





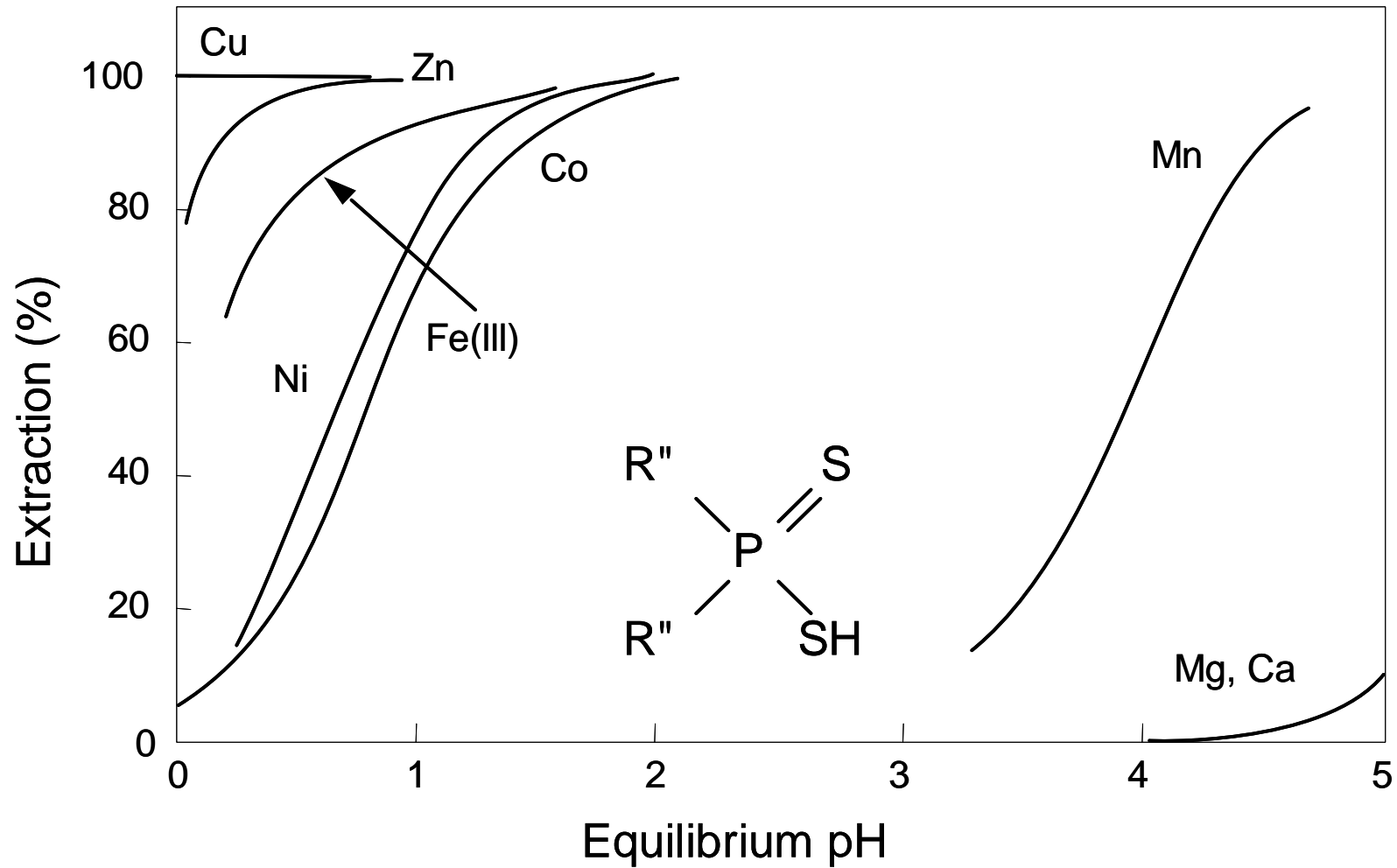

Tertiary Amines (Alamine 308) -
 anionic extractant will extract CoCl_4^{2-}
 and not the neutral complex NiCl_2

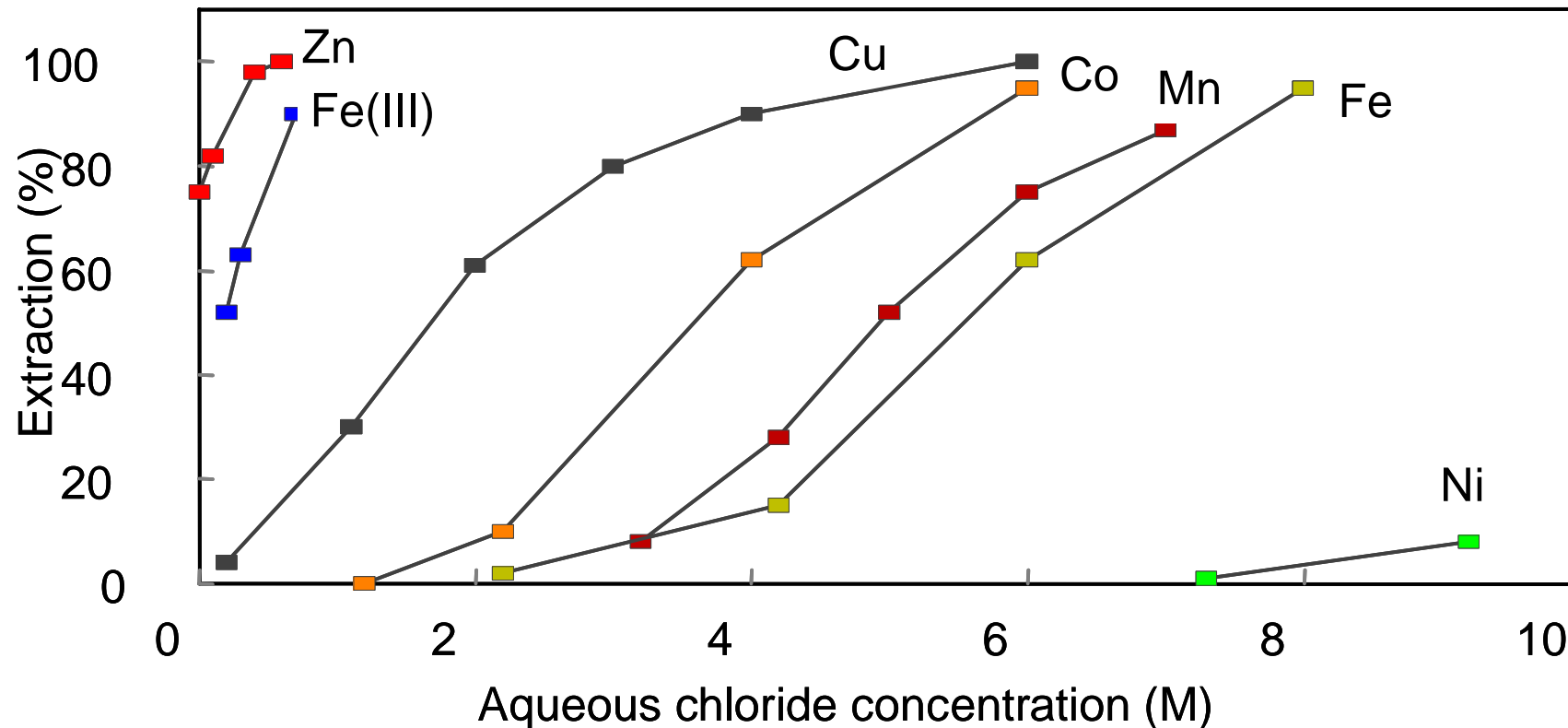

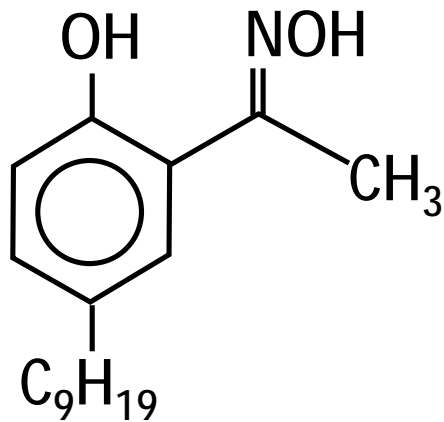

LIX 84-I

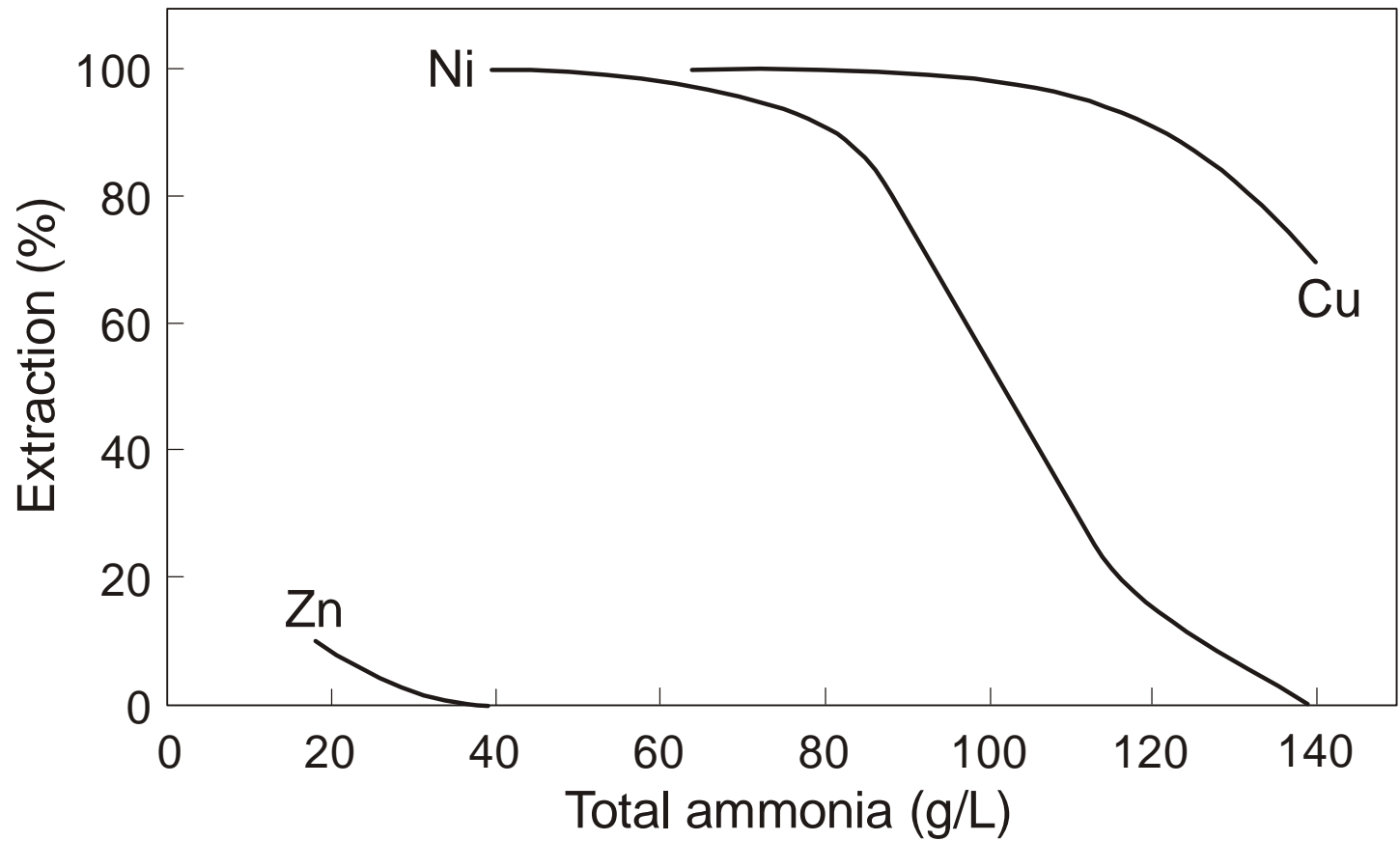

Cawse Ni – Western Australia

CAWSE

